

CONTENT

1. EST (ELECTRICAL SAFETY TEST) RESULTS
2. QUALITY CONTROL CHECK LIST
3. USER MANUAL
4. MULTIPLEXING
5. DIGITAL CONTROLLER MANUALS
6. PARAMETERS
7. ELECTRIC WIRE DIAGRAM (SOME USER MANUALS INCLUDES THIS)

Zu Position 3

2-229
TU-10

Program: NEPTUN PLG
18:30

Date: 24.03.2021

Tester:

Earth Test t= 0.4 s I= 10 AAC Umax= 12 V
AC

Testing by EN 60335

Rmin= 0 mOhm Rmax= 200 mOhm

Time	Resist.	Current	Error
------	---------	---------	-------

Result

18:29:29	63 mOhm	10.98 A	----
OK			

Insulation Test t= 1.0 s U= 1000 V Ustart= 10
0 V Rmin= 5.00 MOhm tRamp= 1.0 s

Time	Resist.	Voltage	Error
------	---------	---------	-------

Result

18:29:32	406 MOhm	1000 V	----
OK			

Flash Test t= 1.0 s U= 1000 VDC Ustart= 100 V
Imin= 0.00 mA Imax= 1.00 mA tRamp= 1.0 s

Time	Current	Voltage	Error
------	---------	---------	-------

Result

18:29:36	0.0 mA	1000 V	----
OK			

Load Test t= 120.0 s tg= 70.0 s Imin= 0.0 A
Imax= 16.0 A

Time	Current	Analog	Error
------	---------	--------	-------

Result

18:30:46	9.4 A	0.0	----
OK			

Programresult=OK

NEPTUN ASSEMBLY QUALITY CONTROL FORM

NO	CONTROLLING THE BODY OF THE CABINET (gövde)	EXAMINED RESULT (sonuç)	CONTROLLED VIA	ACCEPT (kabul)	REFUSE (red)	EXPLANATION
1	GOVDENİN DÜZGÜNLÜK (ÇİZİK,EZİK,DARBE.v.b) KONTROLÜ Check the quality of the carcass re smooth with no bumps or scratches		GOZLE (eye)	✓		
2	KALIBIN ALNI DÜZMU Check that the canopy of the carcass is correct		GOZLE (eye)	✓		
3	AYAK VIDA DELIKLERINE KILAVUZ ÇEKİLDİMİ Case feet can be fitted		KILAVUZLA (by guide)	✓		
4	İZALASYON BANTLARININ KONTROLÜ Check that the all the cabinet joint insulation tape is across each joint		GOZLE (eye)	✓		
	a) POLIURETAN GÖVDE SÜNGER BANTLARI KONTROLÜ Check that all foamed carcass sponge tapes is fitted		GOZLE (eye)	✓		
	b) POLIURETAN GÖVDE ALUMİNYUM BANTLARI KONTROLÜ Check that all foamed carcass aluminium tapes is fitted		GOZLE (eye)	✓		
5	DIREKLERİN VE TAHLİYE İZALASYONUNUN KONTROLÜ, İZOLASYON MADDESİ TAŞMAMALI Check the uprights and drainage insulation, sealant must be kept to a minimum		GOZLE (eye)	✓		
	a) DIREKLERİN SİLİKONU VE MONTAJI DÜZGÜNÜMÜ Check that the silicon is applied with no excess lumps on any joint		GOZLE (eye)	✓		
	b) TAHLİYE DELİKLERİNE PLASTİK CONTA TAKILDIMI Screwed drain pipes in place		GOZLE (eye)	✓		
6	ALIN KONTROLÜ Quality of the canopy area		GOZLE (eye)	✓		
	a) ÇİZİK VE EZİK KONTROLÜ Check that the panel has no scratches & bumps		GOZLE (eye)	✓		
	b) BOYALARI DÜZGÜNÜMÜ Check that the panel is painted correctly		GOZLE (eye)	✓		
7	ÇERÇİVE KASA'YA OTURDULMADAN ÖNCE KABLO YUVASINA MACUN ÇEKİLDİMİ Check if electrical holes are sealed before frame installation		GOZLE (eye)	✓		
8	KASA VE CAMLARIN KONTROLÜ Check the Door insert & glass doors		GOZLE (eye)	✓		
	a) CAMDA ÇİZİK VE HATA VARMI Check that the glass doors have no scratches, other damages & they close correctly.		GOZLE (eye)	✓		
	b) KASALARIN MONTAJI DÜZGÜNÜMÜ Check the fixings that are used to connect the insert to the carcass are correct		GOZLE (eye)	✓		
	c) KAPI CONTLARININ SIKILIĞI YİMİ Check that gaskets on doors are complete with no damages.		EL İLE (manual)	✓		
9	TAVAN SACININ KONTROLÜ Quality of the ceiling panel		GOZLE (eye)	✓		
	a) ÇİZİK VE EZİK KONTROLÜ Check that the panel has no scratches & bumps		GOZLE (eye)	✓		
	b) BOYALARI DÜZGÜNÜMÜ check that the panel is painted correctly		GOZLE (eye)	✓		
10	KABLO VE BORU GİRİŞ DELİKLERİ ALTAN VE ÜSTDEN MACUN İLE KAPATILDIMI Check if the cable and pipe entres sealed from both upper and bottom sides		GOZLE (eye)	✓		
11	TAVA VE PANO KONTROLÜ Quality of the base tray and back panel panels		GOZLE (eye)	✓		
	a) ÇİZİK VE EZİK KONTROLÜ Check that the panels have no scratches or bumps		GOZLE (eye)	✓		
	b) BOYALARI DÜZGÜNÜMÜ Check that the panel is painted correctly		GOZLE (eye)	✓		
12	RAFLAR VE ETİKETLİK TAKILI TAKILMI MI? EPOS + transport clips been fitted.		GOZLE (eye)	✓		
	a) RAFIN RENGİ SİPARİŞE UYGUN MU ? Shelf color		GOZLE (eye)	✓		
	b) ETİKETLİK ADETI DOĞRU MU ? Price-holder quantity		GOZLE (eye)	✓		
13	TEKNİK DOKÜMANLAR SİPARİŞE UYGUN MU? Technical documentation compliant to order		GOZLE (eye)	✓		
14	DOLABIN GENEL TEMİZLİĞİ YAPILDIMI Check that the cabinet is clean & there are no screws, cables, dust & debris anywhere		GOZLE (eye)	✓		
15	POLIURETAN TAŞMALARININ ÖNLENMESİ İÇİN YAN KAPAK KOŞELERİNE BANT VE MACUN ÇEKİLMESİ Applying tape and paste to the side cover corners for preventing polyurethane overflows		GOZLE (eye)	✓		
ELECTRICAL CONTROL (elektrik)						
15	AYDINLATMA ÇALIŞIYORMU Check that all the lights work		GOZLE (eye)	✓		
16	CAM RESİSTANSI ÇALIŞIYORMU Check that the door heaters work		ELEKTRİK SEL ALET (by elec tool)	✓		
17	DIJİTALLERE PROGRAM YÜKLENDİMİ Check that the digital program is installed		GOZLE (eye)	✓		
18	UYARI ETİKETİ ELEKTRİK KUTUSUNUN ÜZERİNE YAPIŞTIRILDI Have the warning stickers been placed on the electrical box		GOZLE (eye)	✓		
19	DIJİTAL KUMANDA SET DEĞERLERİ AYARLANDIMI Check that the digital display has been configured to the CC requirements		EL İLE (manual)	✓		
20	MOTOR FONKSİYON TESTLERİ YAPILDI MI? Plug-in cabinet functional test		GOZLE (eye)	✓		
21	MOTOR KAÇAK TESTİ YAPILDI MI? Plug-in cabinets refrigerant leak test		EST	✓		
NO	CONTROLLING THE CONDENSING UNIT (sogutma)	EXAMINED RESULT (sonuç)	CONTROLLED VIA	ACCEPT (kabul)	REFUSE (red)	EXPLANATION
22	SES - GURULTU KONTROLÜ Check for any unusual noises (rattles, loose components etc)		İŞİTME (audition)	✓		
23	SİSTEMDE GAZ KAÇAĞI TESTİ YAPILDIMI Check that the condensing unit has no gas leaks		DEDEKTÖR - GZEL KİPİK (by delectör)	✓		
24	SOĞUTUCU LAMELLERİNİN DÜZGÜNLÜĞÜNÜN KONTROLÜ Check the condenser fins are not damaged		GOZLE (eye)	✓		
25	UYARI ETİKETİ KONDANSERLERİN ÜZERİNE YAPIŞTIRILDI MI ? Have the warning stickers been placed on the condensers		GOZLE (eye)	✓		
26	SOGUTMA SİSTEMİNDE -20 DERECE GÖRÜLDÜMÜ Run & test the cabinet to make sure it reaches -20 dgr temperature & cycles properly		GOZLE (eye)	✓		
DİĞERLERİ - ADDITIONAL POINTS						
27	SERİ ETİKETİ VERİLERİ DOLABA VE SİPARİŞE UYGUN MU ? rating label compliant to order		GOZLE (eye)	✓		
28	ÖN ALT PANO YAN KAPAKLA UYUMLUDUR Does the machinery grille line up with the end wall (I.E. in line vertically & horizontally)		GOZLE (eye)	✓		
29	ELEKTRİK TEPSİSİ KOLAY ÇIKMALI VE KABLOLAR TAHLİYE REZİSTANSINA KARIŞMAMALI Electrical tray slide out & in easily & the cable does not foul on the condensate heater		GOZLE (eye)	✓		
30	KOMPRESSÖR TEPSİSİ RAHATLIKLA ÇIKMALI Does the machinery tray slide in & out easily + Fit the securing bolt		GOZLE (eye)	✓		
31	SEVKİYAT ARKA DESTEĞİ TAKILDIR Are the rear duct spacers is fitted		GOZLE (eye)	✓		
32	AKSESUARLARIN RENGİ SİPARİŞE UYGUN MU ? Accessories color		GOZLE (eye)	✓		
	a) AKSESUAR PAKETİ MEVCUT MU ? Accessory packaged		GOZLE (eye)	✓		
	b) HAŞARLARI ÖNLEMELİK İÇİN AKSESUAR PAKETİ SABİTLENMİŞ Mİ ? Accessory packing is fixed to cabinet surface to avoid damages/scratches		GOZLE (eye)	✓		
33	KAPILI DOLAPLARDA KAPILAR SABİTLENDİ Mİ ? Doors are included with shipment protection		GOZLE (eye)	✓		
34	SEHBA KALIP DESTEK BAĞLANDIMI Are the corner supports for chassis in place		GOZLE (eye)	✓		
QUALITY CONTROL RESPONSIBLE						
SIGN 						



NEPTUN H PLUG-IN

Installation and User Manual

CONTENT

- 1. Images 2
 - 1.1 Installation Technical Drawing 2
 - 1.2 Transportation 3
 - 1.3 Product Serial ID Plate 3
 - 1.4 Installation and Environmental Factors 3
- 2. Images 4
 - 2.1 MULTIPLEXING 4
- 3. Images 5
- 4. Refrigeration Diagram 6
- 5. Electrical Wiring Diagram 7
- 6. COSMETIC 8
 - 6.1 Cosmetic Parts List 9
- 7. ENGINEERING 10
 - 7.1 Engineering Parts List 11

1. Images

1.1 Installation Technical Drawing

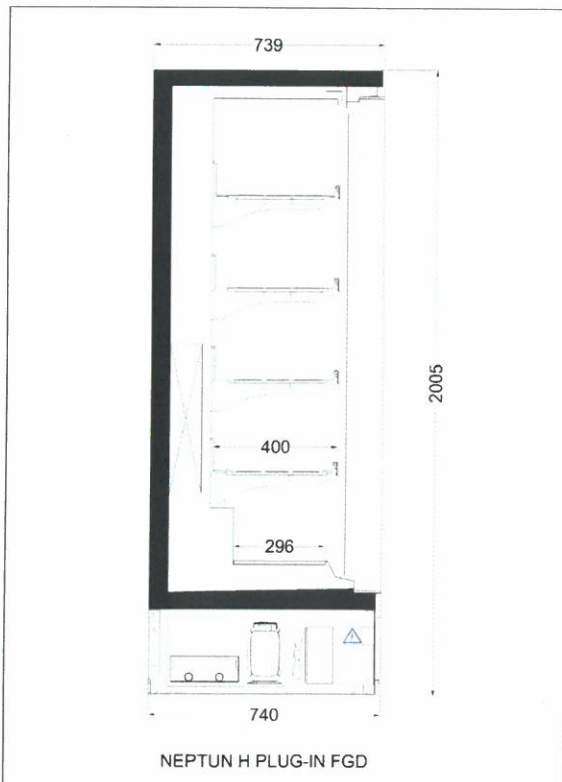

1.2 Transportation

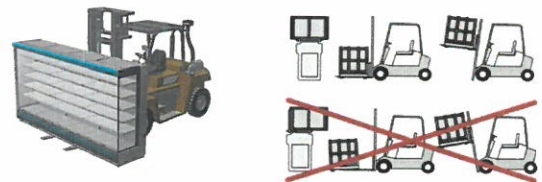

1.3 Product Serial ID Plate

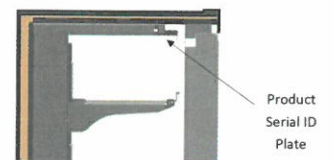

1.4 Installation and Environmental Factors

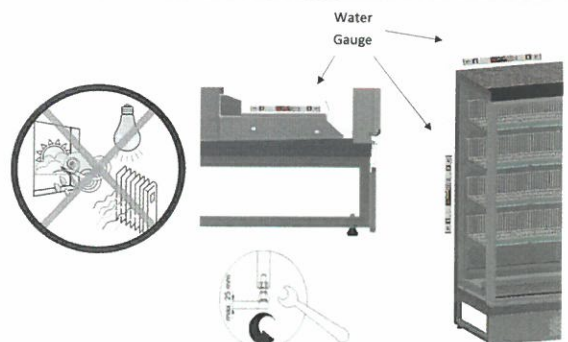

2. Images

2.1 MULTIPLEXING

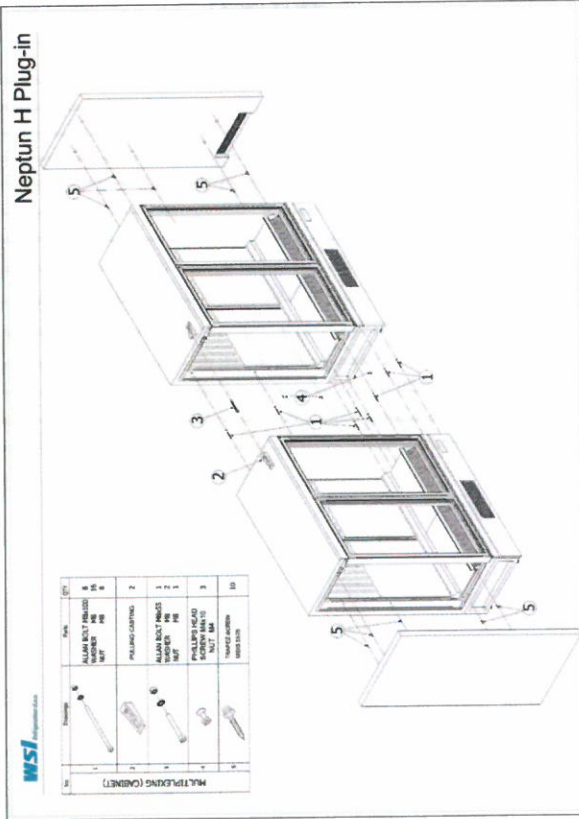

3. Image

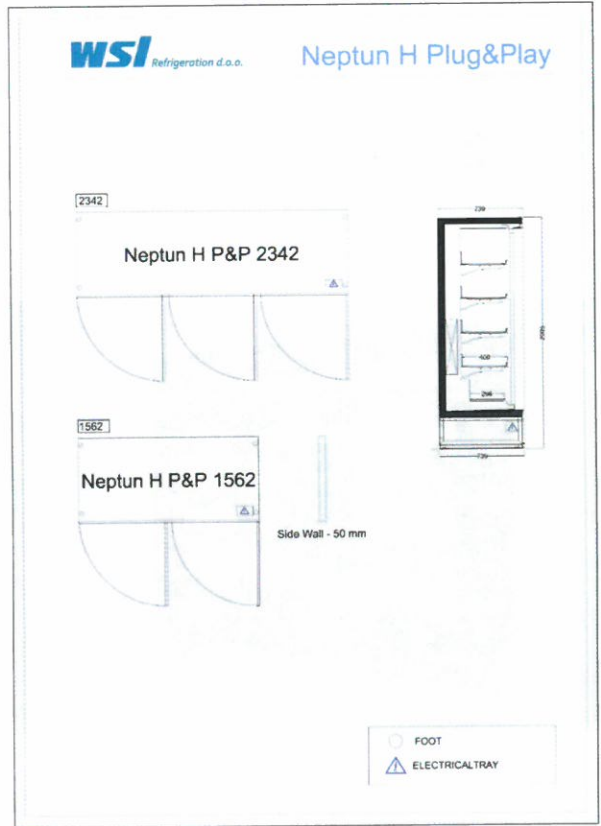

4. Refrigeration Diagram

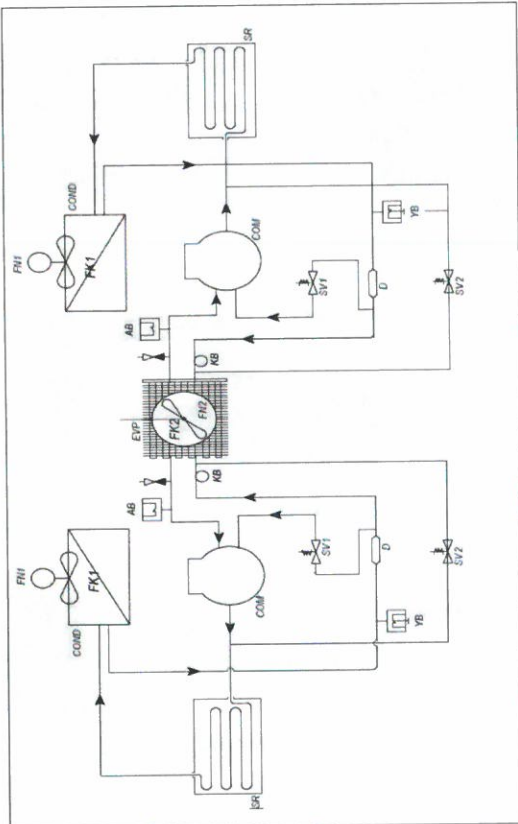

5. Electrical Wiring Diagram

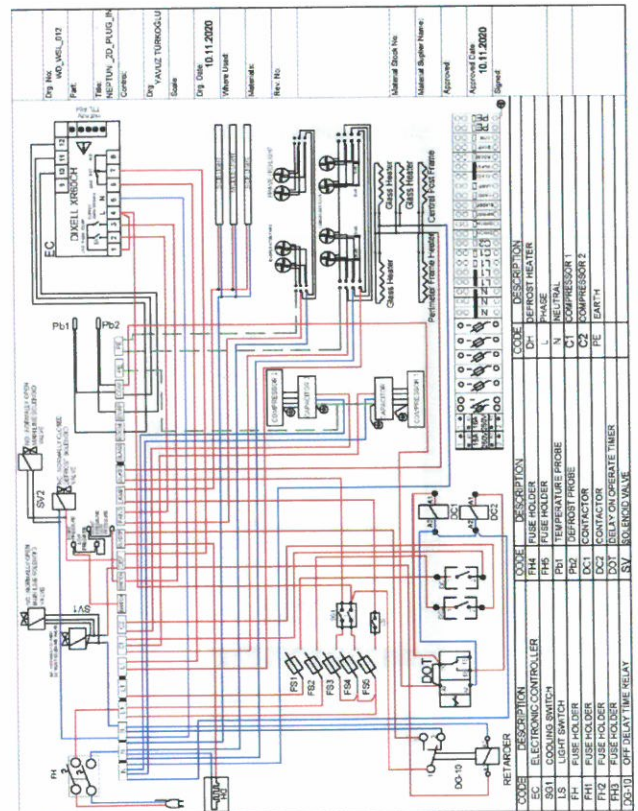

COSMETIC

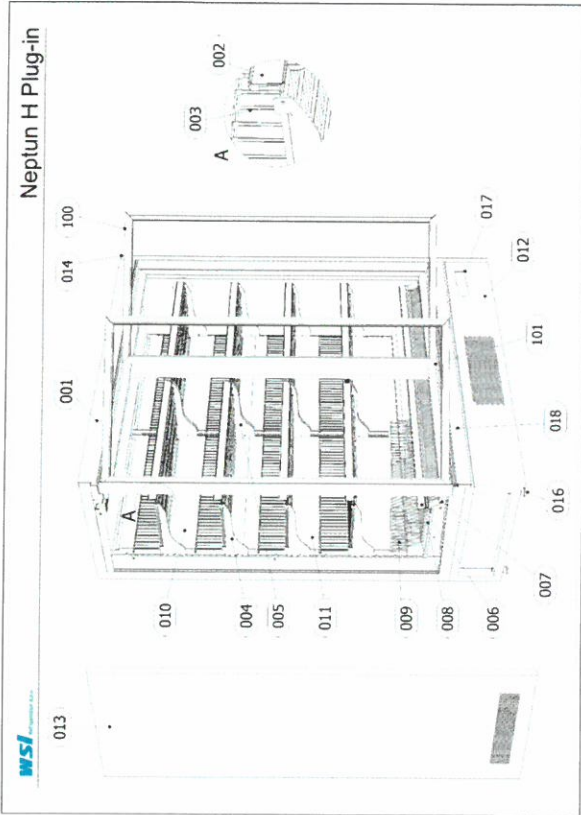

5.1 Cosmetic Parts List

PART NO	PART DESCRIPTION	938 PART NO:	1250 PART NO:	1875 PART NO:	2500 PART NO:
001	CANOPY PROFILE				
002	SHELF TICKET STRIP				
003	WIRE SHELF				
004	RHS SHELF BRACKET				
005	LHS SHELF BRACKET				
006	BASE TICKET STRIP				
007	AIR RETURN GRILL				
008	BASE PLATE				
009	BASE WIRE BASKET				
010	BACK PANEL - TOP				
011	BACK PANEL - BOTTOM				
012	MACHINERY GRILL				
013	BLOCK END WALL GABLE SET				
016	FEET				
017	ISOLATOR COVER				
018	ON RENKLI				
100	FRONT OVERLAY				
101	HINGE				

6. ENGINEERING

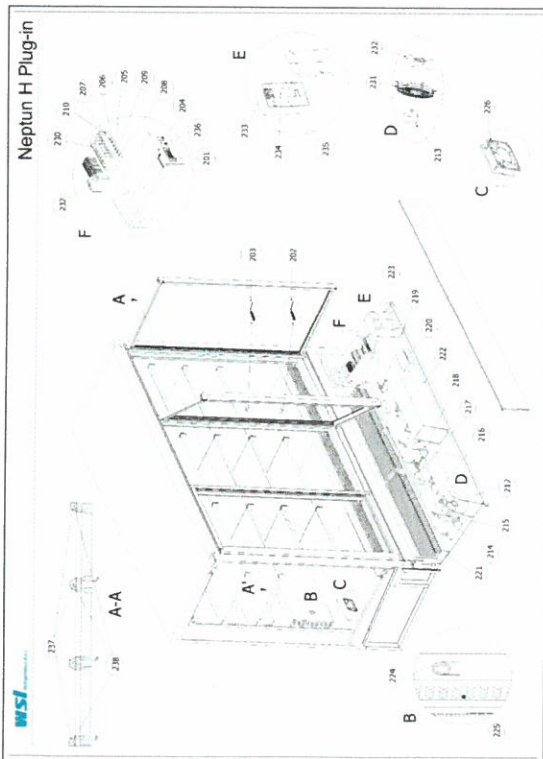

6.1 Engineering Parts List

PART NO	PART DESCRIPTION	938 PART NO:	1250 PART NO:	1875 PART NO:	2500 PART NO:
201	DIGITAL CONTROLLER				
202	PROBE - DEFROST				
203	PROBE - AIR ON				
204	MAIN SWITCH				
205	MBC'S FOR DOOR HEATER				
206	MBC'S FOR LIGHT				
207	MBC'S FOR EVAPARATOR FANS				
208	MBC'S FOR COMPRESSOR - 1				
209	MBC'S FOR COMPRESSOR - 2				
210	CONTACTOR				
211	T8 LED				
212	CONDENSER (Micro Channel)				
213	CONDENSER FAN MOTOR				
214	HIGH PRESSURE SWITCH				
215	LOW PRESSURE SWITCH				
216	COMPRESSOR (R290)				
217	DRIER				
218	SELENOID VALVE - OPEN				
219	SELENOID VALVE - CLOSED				
220	ELECTRICAL BOX				
221	INDUSTRIAL CLOTH				
222	CATHOD				
223	CONDENSATE TRAY				
224	CAPILLARY				
225	EVAPORATOR				
226	EVAPORATOR FAN MOTOR				
230	TIME DELAY RELAY				
231	FAN GAURD METAL				
232	CONTACTOR				
233	START RELAY				
234	RUN CAPACITOR				
235	START CAPACITOR				
236	ON / OFF SWITCH				
237	LIGHTING PROTECTION COVER PLASTIC				

1.1 MULTIPLEXING

Neptun H Plug-in



No	Drawings	Parts	QTY
1		ALLEN BOLT M8x100 WASHER M8 NUT M8	8 16 8
2		PULLING CASTING	2
3		ALLEN BOLT M8x55 WASHER M8 NUT M8	1 2 1
4		PHILLIPS HEAD SCREW M4x10 NUT M4	3
5		TRAPEZ SCREW M8x5.6x75	10

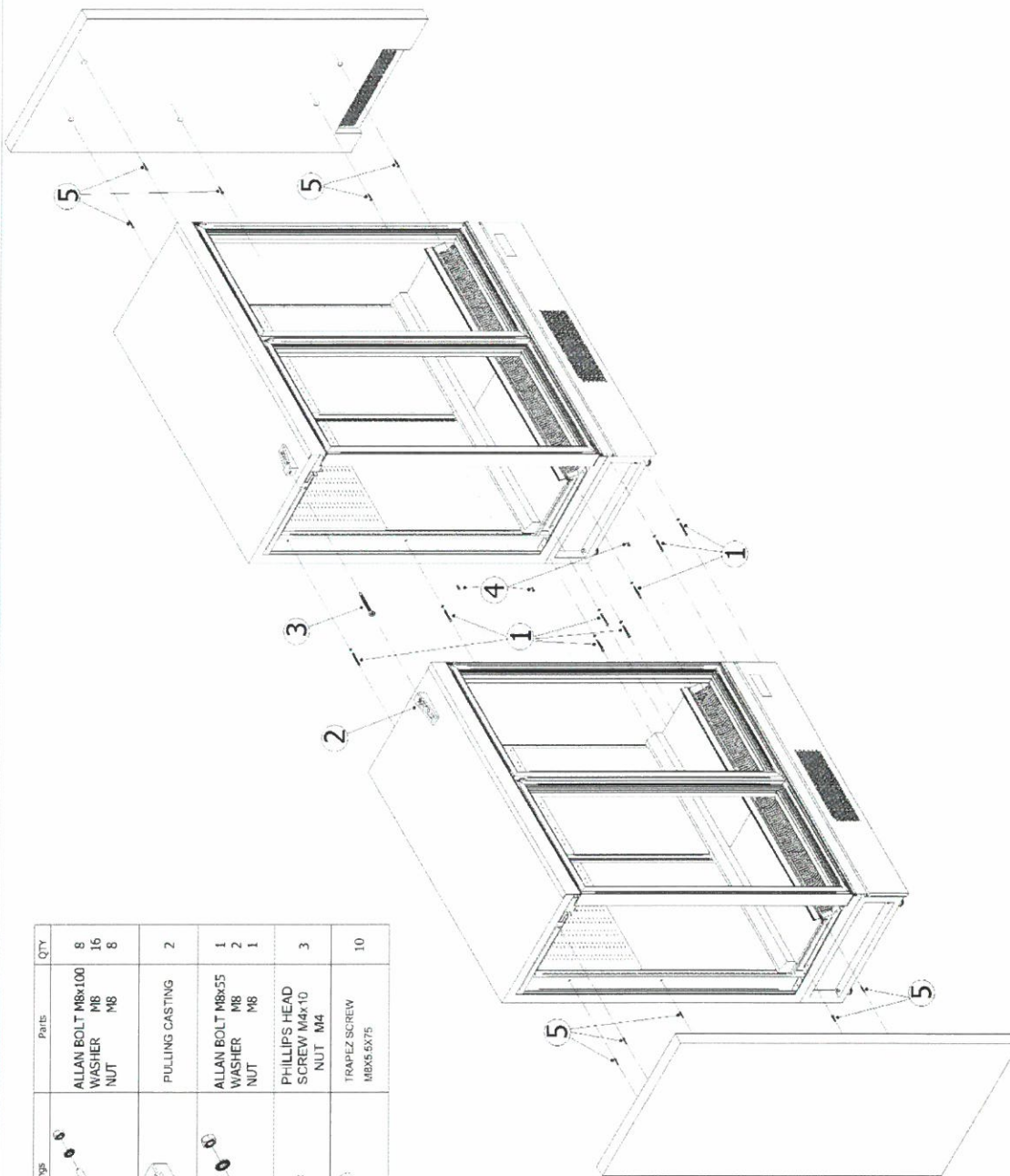

Digital controller with defrost and fan management
XR70CH

CONTENTS

1. GENERAL WARNING	1
2. GENERAL DESCRIPTION	1
3. CONTROLLING LOADS	1
4. FRONT PANEL COMMANDS	1
5. MAX & MIN TEMPERATURE MEMORIZATION	1
6. MAIN FUNCTIONS	2
7. PARAMETERS	2
8. DIGITAL INPUTS	3
9. TTL SERIAL LINE – FOR MONITORING SYSTEMS	3
10. X-REP OUTPUT – OPTIONAL	3
11. INSTALLATION AND MOUNTING	4
12. ELECTRICAL CONNECTIONS	4
13. USE THE HOT KEY	4
14. ALARM SIGNALS	4
15. TECHNICAL DATA	4
16. CONNECTIONS	4
17. DEFAULT SETTING VALUES	5

1. GENERAL WARNING

1.1 PLEASE READ BEFORE USING THIS MANUAL

- This manual is part of the product and should be kept near the instrument for easy and quick reference.
- The instrument shall not be used for purposes different from those described hereunder. It cannot be used as a safety device.
- Check the application limits before proceeding.
- Dixell Srl reserves the right to change the composition of its products, even without notice, ensuring the same and unchanged functionality.

1.2 SAFETY PRECAUTIONS

- Check the supply voltage is correct before connecting the instrument.
- Do not expose to water or moisture: use the controller only within the operating limits avoiding sudden temperature changes with high atmospheric humidity to prevent formation of condensation
- Warning: disconnect all electrical connections before any kind of maintenance.
- Fit the probe where it is not accessible by the End User. The instrument must not be opened.
- In case of failure or faulty operation send the instrument back to the distributor or to "Dixell S.r.l." (see address) with a detailed description of the fault.
- Consider the maximum current which can be applied to each relay (see Technical Data).
- Ensure that the wires for probes, loads and the power supply are separated and far enough from each other, without crossing or intertwining.
- In case of applications in industrial environments, the use of mains filters (our mod. FT1) in parallel with inductive loads could be useful.
- Dixell Srl reserves the right to change the composition of its products, even without notice, ensuring the same and unchanged functionality.

2. GENERAL DESCRIPTION

Model XR70CH, format 32x74mm, is microprocessor based controller, suitable for applications on medium or low temperature ventilated refrigerating units. It has four relay outputs to control compressor, fan, and defrost, which can be either electrical or reverse cycle (hot gas). The last one can be used as light, for alarm signalling or as auxiliary output. It is also provided with up to 4 NTC or PTC probe inputs, the first one for temperature control, the second one, to be located onto the evaporator, to control the defrost termination temperature and to managed the fan. The digital input can operate as third temperature probe. The fourth one, to connect to the HOT KEY terminals, is used to signal the condenser temperature alarm or to display another temperature.

The HOT-KEY output allows to connect the unit, by means of the external module XJ485-CX, to a network line ModBUS-RTU compatible such as the dixell monitoring units of X-WEB family. It allows to program the controller by means the HOT-KEY programming keyboard.

The instrument is fully configurable through special parameters that can be easily programmed through the keyboard.

3. CONTROLLING LOADS

3.1 COMPRESSOR

The regulation is performed according to the temperature measured by the thermostat probe with a positive differential from the set point: if the temperature increases and reaches set point plus differential the compressor is started and then turned off when the temperature reaches the set point value again.

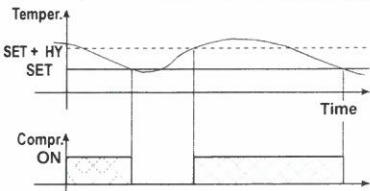

In case of fault in the thermostat probe the start and stop of the compressor are timed through parameters Con and CoF.

3.2 DEFROST

Two defrost modes are available through the tdf parameter: defrost through electrical heater (tdf=EL) and hot gas defrost (tdf=in).

Other parameters are used to control the interval between defrost cycles (idf), its maximum length (Mdf) and two defrost modes: timed or controlled by the evaporator's probe (P2P).

At the end of defrost dripping time is started, its length is set in the Fdt parameter. With Fdt=0 the dripping time is disabled.

3.3 CONTROL OF EVAPORATOR FANS

The fan control mode is selected by means of the FnC parameter:
FnC=C_n, fans will switch ON and OFF with the compressor and **not** run during defrost.
FnC=o_n, fans will run even if the compressor is off, and not run during defrost.

After defrost, there is a timed fan delay allowing for drip time, set by means of the Fnd parameter.
FnC=C_Y, fans will switch ON and OFF with the compressor and **run** during defrost.
FnC=o_Y, fans will run continuously also during defrost.

An additional parameter FSt provides the setting of temperature, detected by the evaporator probe, above which the fans are always OFF. This is used to make sure circulation of air only if his temperature is lower than set in FSt.

3.3.1 Forced activation of fans

This function managed by the Fct parameter is designed to avoid short cycles of fans, that could happen when the controller is switched on or after a defrost, when the room air warms the evaporator.
How it works: if the temperature difference between evaporator probe and room probe is higher than the Fct parameter value, fans will be switched on. With Fct=0 the function is disabled.

3.3.2 Cyclical activation of the fans with compressor off.

When FnC=C-n or C-Y (fans working in parallel with the compressor), by means of the Fon and FoF parameters the fans can carry out on and off cycles even if the compressor is switched off. When the compressor is stopped the fans go on working for the Fon time. With Fon=0 the fans remain always off, also when the compressor is off.

4. FRONT PANEL COMMANDS

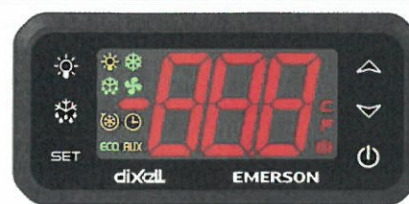

SET	To display target set point; in programming mode it selects a parameter or confirm an operation.
	(DEF) To start a manual defrost.
	(UP) To see the max stored temperature; in programming mode it browses the parameter codes or increases the displayed value.
	(DOWN) To see the min stored temperature; in programming mode it browses the parameter codes or decreases the displayed value.
	To switch the instrument on and off (when onF=oFF).
	To switch on and off the light (when oA3=LiG).

KEY COMBINATIONS:

	To lock & unlock the keyboard.
SET +	To enter in programming mode.
SET +	To return to the room temperature display.

4.1 USE OF LEDS

Each LED function is described in the following table.

LED	MODE	FUNCTION
	ON	Compressor enabled
	Flashing	Anti-short cycle delay enabled
	ON	Defrost enabled
	Flashing	Drip time in progress
	ON	Fans enabled
	Flashing	Fans delay after defrost in progress.
	ON	An alarm is occurring
	ON	Continuous cycle is running
	ON	Energy saving enabled
	ON	Light on
AUX	ON	Auxiliary relay on
°C/°F	ON	Measurement unit
°C/°F	Flashing	Programming phase

5. MAX & MIN TEMPERATURE MEMORIZATION

5.1 HOW TO: SEE THE MIN TEMPERATURE

1. Press and release the DOWN key.
2. The "Lo" message will be displayed followed by the minimum temperature recorded.
3. By pressing the DOWN key again or by waiting 5 sec the normal display will be restored.

5.2 HOW TO: SEE THE MAX TEMPERATURE

1. Press and release the UP key.
2. The "Hi" message will be displayed followed by the maximum temperature recorded.
3. By pressing the UP key again or by waiting 5 sec the normal display will be restored.

5.3 HOW TO: RESET THE MAX AND MIN TEMPERATURE RECORDED

1. Keep the SET key pressed more than 3 sec, while the max or min temperature is displayed. ("rSt" message will be displayed)
2. To confirm the operation the "rSt" message will start blinking and the normal temperature will be displayed.

6. MAIN FUNCTIONS

6.1 HOW TO: SEE THE SET POINT

- SET 
1. Push and immediately release the SET key: the display will show the Set point value.
 2. Push and immediately release the SET key or wait for 5 sec to display the probe value again.

6.2 HOW TO CHANGE THE SET POINT

1. Push the SET key more than 2 sec to change the Set point value.
2. The value of the set point will be displayed and the "°C" or "°F" LED will start blinking.
3. To change the Set value push the UP or DOWN arrows within 10 sec.
4. To save the new set point value, push the SET key again or wait for 10 sec.

6.3 HOW TO START A MANUAL DEFROST

-  Push the DEF key for more than 2 sec and a manual defrost will start.

6.4 HOW TO: CHANGE A PARAMETER VALUE

To change a parameter value, operate as follows:

1. Enter the Programming mode by pressing the SET+DOWN buttons for 3s (the °C or °F LED will start blinking).
2. Select the required parameter. Press the SET button to display its actual value.
3. Use UP or DOWN buttons to change its value.
4. Press SET button to store the new value and move to the following parameter.

To exit: Press SET + UP buttons or waiting for 15s without pressing any key.

NOTE: the set value is stored even when the procedure is exited by waiting for the time-out to expire.

6.5 THE HIDDEN MENU

The hidden menu includes all the parameters of the instrument.

6.5.1 HOW TO: ENTER THE HIDDEN MENU

1. Enter the Programming mode by pressing the SET+DOWN buttons for 3 sec (the °C or °F LED will start blinking).
2. Released the buttons and then push again the SET+DOWN buttons for more than 7s. The Pr2 label will be displayed immediately followed from the HY parameter.
Now it is possible to browse the hidden menu.
3. Select the required parameter.
4. Press the SET button to display its value.
5. Use UP or DOWN to change its value.
6. Press SET to store the new value and move to the following parameter.

To exit: Press SET+DOWN or wait 15 sec without pressing a key.

NOTE1: if no parameter is present in Pr1 menu, after 3 sec the "noP" message will be displayed. Keep the buttons pushed till the Pr2 message will be displayed.

NOTE2: the set value is stored even when the procedure is exited by waiting for the time-out to expire

6.5.2 HOW TO: MOVE A PARAMETER FROM THE HIDDEN MENU TO THE FIRST LEVEL AND VICEVERSA.

Each parameter present in the hidden menu (Pr2) can be moved into the user level (Pr1) by pressing SET+DOWN buttons. If a parameter is part of the user level, when showed in the hidden menu the decimal point will be lit.

6.6 HOW TO: LOCK THE KEYBOARD

1. Keep both UP and DOWN buttons pressed for more than 3 sec.
2. The "PoF" message will be displayed and the keyboard will be locked. At this point it will be possible only to see the set point or the MAX o Min temperature stored
3. If a button is pressed more than 3 sec the "PoF" message will be displayed

6.7 HOW TO: UNLOCK THE KEYBOARD

Keep pressed together for more than 3 sec the UP and DOWN keys till the "Pon" message will be displayed.

6.8 THE CONTINUOUS CYCLE

When defrost is not in progress, it can be activated by holding the UP key pressed for about 3 sec. The compressor operates to maintain the CCS set point for the time set through the CCT parameter. The cycle can be terminated before the end of the set time using the same activation key UP for 3 sec.

6.9 THE ON/OFF FUNCTION

-  With "onF = oFF", pushing the ON/OFF key, the instrument is switched off. The "OFF" message is displayed. In this configuration, the regulation is disabled. To switch the instrument on, push again the ON/OFF key.

WARNING: Loads connected to the normally closed contacts of the relays are always supplied and under voltage, even if the instrument is in stand by mode.

7. PARAMETERS

REGULATION

HY	Differential: (0.1 to 25.5°C; 1 to 45°F) intervention differential for set point. Compressor Cut IN is Set Point + differential (HY). Compressor Cut OUT is when the temperature reaches the set point.
LS	Minimum set point: (-100°C to SET; -148°F to SET) sets the minimum value for the set point.
US	Maximum set point: (SET to 150°C; SET to 302°F) set the maximum value for set point.
ot	Thermostat probe calibration: (-12.0 to 12.0°C; -21 to 21°F) allows to adjust possible offset of the thermostat probe.
P2P	Evaporator probe presence: (n; Y) n = not present, the defrost stops by time; Y = present, the defrost stops by temperature.
oE	Evaporator probe calibration: (-12.0 to 12.0°C; -21 to 21°F) allows to adjust possible offset of the evaporator probe.
P3P	Third probe presence (P3): (n; Y) n = not present, the terminals 18-20 operate as digital input; Y = present, the terminals 18-20 operate as third probe.
o3	Third probe calibration (P3): (-12.0 to 12.0°C; -21 to 21°F) allows to adjust possible offset of the third probe.
P4P	Fourth probe presence: (n; Y) n = Not present; Y = present.
o4	Fourth probe calibration: (-12.0 to 12.0°C; -21 to 21°F) allows to adjust possible offset of the fourth probe.
odS	Outputs activation delay at start up: (0 to 255min) this function is enabled at the initial start up of the instrument and inhibits any output activation for the period of time set in the parameter.
AC	Anti-short cycle delay: (0 to 50min) minimum interval between the compressor stop and the following restart.
rtr	Percentage of the second and first probe for regulation: (0 to 100; 100=P1, 0=P2) it allows to set the regulation according to the percentage of the first and second probe, as for the following formula (rtr(P1-P2)/100 + P2).
CCt	Compressor ON time during continuous cycle: (0.0 to 24h00min, res. 10min) allows to set the length of the continuous cycle. Compressor stays on without interruption during CCt time. This is useful, for instance, when the room is filled with new products.
CCS	Set point for continuous cycle: (-55 to 150°C; -67 to 302°F) it sets the set point used during the continuous cycle.
Con	Compressor ON time with faulty probe: (0 to 255min) time during which the compressor is active in case of faulty thermostat probe. With Con=0 compressor is always OFF.
CoF	Compressor OFF time with faulty probe: (0 to 255min) time during which the compressor is OFF in case of faulty thermostat probe. With CoF=0 compressor is always active.

DISPLAY

CF	Temperature measurement unit: (°C; °F) °C = Celsius; °F = Fahrenheit. WARNING: When the measurement unit is changed the SET point and the values of the parameters HY, LS, US, ot, ALU and ALL have to be checked and modified (if necessary).
rES	Resolution (for °C): (in=1°C; dE=0.1°C) allows decimal point display.
Lod	Instrument display: (P1; P2, P3, P4, SET, dtr) it selects which probe is displayed by the instrument. P1 = Thermostat probe; P2 = Evaporator probe; P3 = Third probe (only for model with this option enabled); P4 = Fourth probe, SET = set point; dtr = percentage of visualization.
rEd	X-REP display (optional): (P1; P2, P3, P4, SET, dtr) it selects which probe is displayed by X- REP. P1 = Thermostat probe; P2 = Evaporator probe; P3 = Third probe (only for model with this option enabled); P4 = Fourth probe, SET = set point; dtr = percentage of visualization.
dLY	Display delay: (0 to 20min00s; res. 10s) when the temperature increases, the display is updated of 1°C or 1°F after this time.
dtr	Percentage of the second and first probe for visualization when Lod=dtr: (0 to 99; 100=P1, 0=P2) if Lod=dtr it allows to set the visualization according to the percentage of the first and second probe, as for the following formula (dtr(P1-P2)/100 + P2).

DEFROST

tdF	Defrost type: (EL; in) EL = electrical heater; in = hot gas.
dFP	Probe selection for defrost termination: (nP; P1; P2; P3; P4) nP = no probe; P1 = thermostat probe; P2 = evaporator probe; P3 = configurable probe; P4 = Probe on Hot Key plug.
dtE	Defrost termination temperature: (-55 to 50°C; -67 to 122°F) (enabled only when EdF=Pb) sets the temperature measured by the evaporator probe, which causes the end of defrost.
idF	Interval between defrost cycles: (0 to 120hours) determines the interval of time between two defrost cycles.
MdF	(Maximum) length for defrost: (0 to 255min) when P2P=n, (not evaporator probe: timed defrost) it sets the defrost duration. When P2P=Y (defrost end based on temperature) it sets the maximum length for defrost.
dSd	Start defrost delay: (0 to 99min) this is useful when different defrost start times are necessary to avoid overloading the plant.
dFd	Temperature displayed during defrost: (rt; it; SET; dEF) rt = real temperature; it = temperature at defrost start; SET = set point; dEF = "dEF" label.
dAd	MAX display delay after defrost: (0 to 255min) sets the maximum time between the end of defrost and the restarting of the real room temperature display.
Fdt	Drift time: (0 to 120min) time interval between reaching defrost termination temperature and the restoring of the control's normal operation. This time allows the evaporator to eliminate water drops that might have formed due to defrost.
dPo	First defrost after start-up: (n; Y) <ul style="list-style-type: none"> • n = after the idF time, • Y = immediately.
dAF	Defrost delay after continuous cycle: (0.0 to 24h00min, res. 10min) time interval between the end of the fast freezing cycle and the following defrost related to it.

FANS	
FnC	Fans operating mode: (C-n; o-n; C-Y; o-Y) C-n = runs with the compressor, OFF during defrost; o-n = continuous mode, OFF during defrost; C-Y = runs with the compressor, ON during defrost; o-Y = continuous mode, ON during defrost.
Fnd	Fans delay after defrost: (0 to 255min) interval between end of defrost and evaporator fans start.
FCT	Temperature differential to avoid fan short cycles: (0 to 59°C; 0 to 90°F) (N.B.: if FCT=0 function disabled) if the difference of temperature between the evaporator and the room probes is higher than FCT value, the fans will be switched on.
FSt	Fans stop temperature: (-55 to 50°C; -67 to 122°F) setting of temperature, detected by evaporator probe, above which fans are always OFF.
Fon	Fan ON time: (0 to 15min) with Fnc=C_n or C_Y, (fan activated in parallel with compressor) it sets the evaporator fan ON cycling time when the compressor is off. With Fon=0 and FoF≠0 the fan are always off, with Fon=0 and FoF=0 the fan are always off.
FoF	Fan OFF time: (0 to 15min) With Fnc=C_n or C_Y, (fan activated in parallel with compressor) it sets the evaporator fan off cycling time when the compressor is off. With Fon=0 and FoF≠0 the fan are always off, with Fon=0 and FoF=0 the fan are always off.
FAP	Probe selection for fan management: (nP; P1; P2; P3; P4) nP = no probe; P1 = thermostat probe; P2 = evaporator probe; P3 =configurable probe; P4 = Probe on Hot Key plug.

ALARMS	
ALC	Temperature alarms configuration: (Ab; rE) Ab = absolute temperature, alarm temperature is given by the ALL or ALU values. rE = temperature alarms are referred to the set point. Temperature alarm is enabled when the temperature exceeds the [SET+ALU] or [SET-ALL] values.
ALU	MAXIMUM temperature alarm: <ul style="list-style-type: none"> If ALC=Ab: [ALL to 150.0°C or ALL to 302°F] If ALC=rE: [0.0 to 50.0°C or 0 to 90°F] when this temperature is reached the alarm is enabled, after the ALD delay time.
ALL	Minimum temperature alarm: <ul style="list-style-type: none"> If ALC=Ab: [-100°C to ALU; -148 to ALU] If ALC=rE: [0.0 to 50.0°C or 0 to 90°F] when this temperature is reached the alarm is enabled, after the ALD delay time.
AFH	Differential for temperature alarm recovery: (0.1 to 25.5°C; 1 to 45°F) intervention differential for recovery of temperature alarm.
ALd	Temperature alarm delay: (0 to 255 min) time interval between the detection of an alarm condition and alarm signalling.
dAo	Exclusion of temperature alarm at start-up: (0.0 to 24h00min, res. 10min) time interval between the detection of the temperature alarm condition after instrument power on and alarm signalling.

CONDENSER TEMPERATURE ALARM	
AP2	Probe selection for temperature alarm of condenser: (nP; P1; P2; P3; P4) nP = no probe; P1 = thermostat probe; P2 = evaporator probe; P3 = configurable probe; P4 = Probe on Hot Key plug.
AL2	Low temperature alarm of condenser: (-100 to 150°C; -148 to 302°F) when this temperature is reached the LA2 alarm is signalled, possibly after the Ad2 delay.
Au2	High temperature alarm of condenser: (-100 to 150°C; -148 to 302°F) when this temperature is reached the HA2 alarm is signalled, possibly after the Ad2 delay.
AH2	Differential for temperature condenser alarm recovery: 0.1 to 25.5°C; 1 to 45°F
Ad2	Condenser temperature alarm delay: (0 to 255 min) time interval between the detection of the condenser alarm condition and alarm signalling.
dA2	Condenser temperature alarm exclusion at start up: 0.0 to 24h00min, res. 10min.
bLL	Compressor off with low temperature alarm of condenser: (n; Y) n = compressor keeps on working; Y = compressor is switched off till the alarm is present, in any case regulation restarts after AC time at minimum.
AC2	Compressor off with high temperature alarm of condenser: (n; Y) n = compressor keeps on working; Y = compressor is switched off till the alarm is present, in any case regulation restarts after AC time at minimum.

FOURTH RELAY	
tbA	Alarm relay silencing (with oA3 =ALr): (n; Y) n = silencing disabled: alarm relay stays on till alarm condition lasts. Y = silencing enabled: alarm relay is switched OFF by pressing a key during an alarm.
oA3	Second relay configuration (1-4): (dEF; FAn; ALr; LiG; AUS; onF; db; dEF2; HES) dEF = defrost; FAn = do not select it; ALr = alarm; LiG = light; AUS = Auxiliary relay; onF = always on with instrument on; db = neutral zone; dEF2 = do not select it; HES = night blind.
AoP	Alarm relay polarity: (CL; oP) it set if the alarm relay is open or closed when an alarm occurs. CL = terminals 1-4 closed during an alarm; oP = terminals 1-4 open during an alarm.

DIGITAL INPUTS	
i1P	Second digital input polarity: (oP; CL) oP = the digital input is activated by opening the contact; CL = the digital input is activated by closing the contact.
i1F	Second digital input configuration: (EAL; bAL; PAL; dor; dEF; ES; AUS; Htr; FAn; HdF; onF) EAL = external alarm: "EA" message is displayed; bAL = serious alarm "CA" message is displayed; PAL = pressure switch alarm, "CA" message is displayed; dor = door switch function; dEF = activation of a defrost cycle; ES = energy saving; AUS = auxiliary relay activation with oA3=AUS; Htr = type of inverting action (cooling or heating); FAn = fan; HdF = Holiday defrost (enable only with RTC); onF = to switch the controller off.
did	Digital input 1 alarm delay: (0 to 255 min) delay between the detection of the external alarm condition and its signalling. When i1F= PAL, it is the interval of time to calculate the number of pressure switch activation.

nPS	Number of pressure switch activation: (0 to 15) Number of activation, during the did or d2d interval, before signalling an alarm event (i1F, i2F=PAL). If the nPS activation during did or d2d time is reached, switch off and on the instrument to restart normal regulation.
odC	Compressor status when open door: (no; FAn; CPr; F_C) no = normal; FAn = normal; CPr = compressor OFF; F_C = compressor OFF.
rrd	Outputs restart after door open alarm: (n; Y) n = outputs follow the odC parameter. Y = outputs restart with a door open alarm.
HES	Delta temperature during an Energy Saving cycle: (-30.0 to 30.0°C; -54 to 54°F) it sets the increasing value of the set point [SET+HES] during the Energy Saving cycle.

OTHER	
Adr	Serial address: (1 to 247) identifies the instrument address when connected to a ModBUS compatible monitoring system.
PbC	Type of probe: (PtC; nTC) it allows to set the kind of probe used by the instrument: PtC = PTC probe, nTC = NTC probe.
onF	On/Off key enabling: (nU; oFF; ES) nU = disabled; oFF = enabled; ES = not set it.
dP1	Thermostat probe display.
dP2	Evaporator probe display.
dP3	Third probe display- optional.
dP4	Fourth probe display.
rSE	Real set point: it shows the set point used during the energy saving cycle or during the continuous cycle.
rEL	Software release for internal use.
Ptb	Parameter table code: readable only.

8. DIGITAL INPUTS

The free voltage digital input is programmable by the i1F parameter.

8.1 GENERIC ALARM (i1F = EAL)

As soon as the digital input is activated the unit will wait for did time delay before signalling the EAL alarm message. The outputs statuses don't change. The alarm stops just after the digital input is deactivated.

8.2 SERIOUS ALARM MODE (i1F = BAL)

When the digital input is activated, the unit will wait for did delay before signalling the CA alarm message. The relay outputs are switched OFF. The alarm will stop as soon as the digital input is deactivated.

8.3 PRESSURE SWITCH (i1F = PAL)

If during the interval time set by did parameter, the pressure switch has reached the number of activation of the nPS parameter, the CA pressure alarm message will be displayed. The compressor and the regulation are stopped. When the digital input is ON the compressor is always OFF. If the nPS activation in the did time is reached, switch off and on the instrument to restart normal regulation.

8.4 DOOR SWITCH INPUT (i1F = DOR)

It signals the door status and the corresponding relay output status through the odC parameter: no = normal (any change); FAn = Fan OFF; CPr = Compressor OFF; F_C = Compressor and fan OFF. Since the door is opened, after the delay time set through parameter doA, the door alarm is enabled, the display shows the message dA and the regulation restarts is rtr=YES. The alarm stops as soon as the external digital input is disabled again. With the door open, the high and low temperature alarms are disabled.

8.5 START DEFROST (i1F = DEF)

It starts a defrost if there are the right conditions. After the defrost is finished, the normal regulation will restart only if the digital input is disabled otherwise the instrument will wait until the "MdF" safety time is expired.

8.6 SWITCH THE AUXILIARY RELAY (i1F = AUS)

With oA3 = AUS the digital input switched the status of the auxiliary relay

8.7 INVERSION OF THE KIND OF ACTION: HEATING-COOLING (i1F=HTR)

This function allows to invert the regulation of the controller: from cooling to heating and viceversa.

8.8 ENERGY SAVING (i1F = ES)

The Energy Saving function allows to change the set point value as the result of the SET+ HES (parameter) sum. This function is enabled until the digital input is activated.

8.9 ON OFF FUNCTION (i1F = ONF)

To switch the controller on and off.

8.10 DIGITAL INPUT POLARITY

The digital input polarity depends on the i1P parameter.
i1P = CL: the input is activated by closing the contact
i1P = oP: the input is activated by opening the contact

9. TTL SERIAL LINE – FOR MONITORING SYSTEMS

The TTL serial line, available through the HOT KEY connector, allows to connect the instrument to a monitoring system ModBUS-RTU compatible such as the XWEB500.

10. X-REP OUTPUT – OPTIONAL

As optional, an X-REP can be connected to the instrument, through the dedicated connector.



To connect the X-REP to the instrument the following connectors must be used CAB-51F(1m), CAB-52F(2m), CAB-55F(5m).

11. INSTALLATION AND MOUNTING

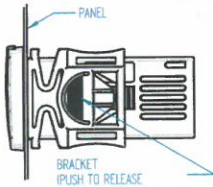

Instrument XR70CH shall be mounted on vertical panel, in a 29x71 mm hole, and fixed using the special bracket supplied. The temperature range allowed for correct operation is 0 to 60°C. Avoid places subject to strong vibrations, corrosive gases, excessive dirt or humidity. The same recommendations apply to probes. Let air circulate by the cooling holes.

12. ELECTRICAL CONNECTIONS

The instrument is provided with screw terminal block to connect cables with a cross section up to 2.5mm². Before connecting cables make sure the power supply complies with the instrument's requirements. Separate the probe cables from the power supply cables, from the outputs and the power connections. Do not exceed the maximum current allowed on each relay, in case of heavier loads use a suitable external relay.

12.1 PROBE CONNECTION

The probes shall be mounted with the bulb upwards to prevent damages due to casual liquid infiltration. It is recommended to place the thermostat probe away from air streams to correctly measure the average room temperature. Place the defrost termination probe among the evaporator fins in the coldest place, where most ice is formed, far from heaters or from the warmest place during defrost, to prevent premature defrost termination.

13. USE THE HOT KEY

13.1 HOW TO: PROGRAM A HOT KEY FROM THE INSTRUMENT (UPLOAD)

1. Program one controller with the front keypad.
2. When the controller is ON, insert the "HOT-KEY" and push UP button; the "uPL" message appears followed a by a flashing "End" label.
3. Push SET button and the "End" will stop flashing.
4. Turn OFF the instrument, remove the "HOT-KEY" and then turn it ON again.

NOTE: the "Err" message appears in case of a failed programming operation. In this case push again button if you want to restart the upload again or remove the "HOT-KEY" to abort the operation.

13.2 HOW TO: PROGRAM AN INSTRUMENT USING A HOT KEY (DOWNLOAD)

1. Turn OFF the instrument.
2. Insert a pre-programmed "HOT-KEY" into the 5-PIN receptacle and then turn the Controller ON.
3. The parameter list of the "HOT-KEY" will be automatically downloaded into the Controller memory. The "dOL" message will blink followed a by a flashing "End" label.
4. After 10 seconds the instrument will restart working with the new parameters.
5. Remove the "HOT-KEY".

NOTE: the message "Err" is displayed for failed programming. In this case turn the unit off and then on if you want to restart the download again or remove the "HOT-KEY" to abort the operation.

14. ALARM SIGNALS

Message	Cause	Outputs
"P1"	Room probe failure	Compressor output acc. to par. Con and CoF
"P2"	Evaporator probe failure	Defrost end is timed
"P3"	Third probe failure	Outputs unchanged
"P4"	Fourth probe failure	Outputs unchanged
"HA"	Maximum temperature alarm	Outputs unchanged.
"LA"	Minimum temperature alarm	Outputs unchanged.
"HA2"	Condenser high temperature	It depends on the AC2 parameter
"LA2"	Condenser low temperature	It depends on the bLL parameter
"dA"	Door open	Compressor and fans restarts
"EA"	External alarm	Output unchanged.
"CA"	Serious external alarm (i2F=bAL)	All outputs OFF.
"CA"	Pressure switch alarm (i2F=PAL)	All outputs OFF
"rtc"	Real time clock alarm	Alarm output ON; Other outputs unchanged; Defrosts according to par. idF Set real time clock has to be set
rtF	Real time clock board failure	Alarm output ON; Other outputs unchanged; Defrosts according to par. idF Contact the service

14.1 ALARM RECOVERY

Probe alarms "P1", "P2", "P3" and "P4" start some seconds after the fault in the related probe; they automatically stop some seconds after the probe restarts normal operation. Check connections before replacing the probe. Temperature alarms "HA", "LA", "HA2" and "LA2" automatically stop as soon as the temperature returns to normal values. Alarms "EA" and "CA" (with i2F=bAL) recover as soon as the digital input is disabled. Alarm "CA" (with i2F=PAL) recovers only by switching off and on the instrument.

14.2 OTHER MESSAGES

Pon	Keyboard unlocked.
poF	Keyboard locked
noP	In programming mode: none parameter is present in Pr1 On the display or in dP2, dP3, dP4: the selected probe is nor enabled

15. TECHNICAL DATA

Housing: self extinguishing ABS.
Case: frontal 38x80 mm; depth 62mm;
Mounting: panel mounting in a 71x29mm panel cut-out
Protection: IP20; **Frontal protection:** IP65
Connections: Screw terminal block ≤ 2.5 mm² wiring
Power supply: according to the model
 12VAC/DC, ±10%
 110AC ±10%, 50/60Hz
 230VAC ±10%, 50/60Hz
Power absorption: 3VA max
Display: 3 digits, red LED, 14.2 mm high
Inputs: Up to 4 NTC or PTC probes
Digital inputs: free voltage contact
Relay outputs: compressor SPST 8(3) A, 250VAC or SPST 16A 250VAC
Defrost: SPDT 8(3) A, 250VAC
Fan: SPST 5A, 250VAC
Aux: SPDT 8(3) A, 250VAC
Buzzer: optional
Data storing: on the non-volatile memory (EEPROM)
Internal clock back-up: 24 hours
Kind of action: 1B
Pollution degree: 2
Software class: A
Rated impulsive voltage: 2500V
Overvoltage Category: II
Operating temperature: 0 to 55°C
Storage temperature: -25 to 60°C
Relative humidity: 20 to 85% (no condensing)
Measuring and regulation range:
 NTC probe: -40 to 110°C (-40 to 230°F)
 PTC probe: -100 to 150°C (-148 to 302°F)
Resolution: 0.1°C or 1°C or 1°F (selectable)
Accuracy (ambient temp. 25°C): ±0.7°C ±1 digit

16. CONNECTIONS

The X-REP output excludes the TTL output.. It's present in the following codes: XR70CH- xx2xx, XR70CH-xx3xx;

16.1 XR70CH – 8A OR 16A COMP. RELAY - 230VAC OR 110VAC

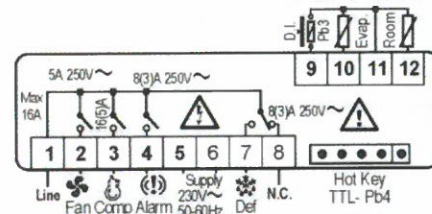

NOTE: The compressor relay is 8(3)A or 16(6)A according to the model. 24Vac supply: connect to the terminals 5 and 6.

16.2 XR70CH – 4 X 16A - 12VAC/DC

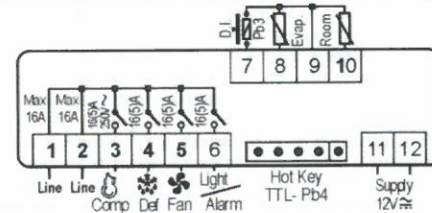

17. DEFAULT SETTING VALUES

Label	Name	Range	Value	Level
SEt	Set point	LS; US	-5.0	---
HY	Differential	[0.1 to 25.5°C] [1 to 45°F]	2.0	Pr1
LS	Minimum set point	[-100°C to SET] [-148°F to SET]	-50.0	Pr2
US	Maximum set point	[SET to 150°C] [SET to 302°F]	110	Pr2
ot	Thermostat probe calibration	[-12.0 to 12.0°C] [-21 to 21°F]	0.0	Pr1
P2P	Evaporator probe presence	n; Y	Y	Pr1
oE	Evaporator probe calibration	[-12.0 to 12.0°C] [-21 to 21°F]	0.0	Pr2
P3P	Third probe presence	n; Y	n	Pr2
o3	Third probe calibration	[-12.0 to 12.0°C] [-21 to 21°F]	0	Pr2
P4P	Fourth probe presence	n; Y	n	Pr2
o4	Fourth probe calibration	[-12.0 to 12.0°C] [-21 to 21°F]	0	Pr2
odS	Outputs delay at start up	0 to 255 min	0	Pr2
AC	Anti-short cycle delay	0 to 50 min	1	Pr1
rtr	P1-P2 percentage for regulation	0 to 100 (100=P1, 0=P2)	100	Pr2
CCt	Continuous cycle duration	0.0 to 24h00min, res. 10 min	0.0	Pr2
CCS	Set point for continuous cycle	[-100 to 150.0°C] [-148 to 302°F]	-5	Pr2
Con	Compressor ON time with faulty probe	0 to 255 min	15	Pr2
CoF	Compressor OFF time with faulty probe	0 to 255 min	30	Pr2
CF	Temperature measurement unit	°C; °F	°C	Pr2
rES	Resolution	dE; in	dE	Pr1
Lod	Probe displayed	P1; P2; P3; P4; SEt; dtr	P1	Pr2
rEd²	X-REP display	P1; P2; P3; P4; SEt; dtr	P1	Pr2
dLY	Display temperature delay	0.0 to 20min00sec, res. 10 sec	0.0	Pr2
dtr	P1-P2 percentage for display	1 to 99	50	Pr2
tdF	Defrost type	EL; in	EL	Pr1
dFP	Probe selection for defrost termination	nP; P1; P2; P3; P4	P2	Pr2
dtE	Defrost termination temperature	[-55 to 50.0°C] [-67 to 122°F]	8	Pr1
idF	Interval between defrost cycles	0 to 120 hours	6	Pr1
MdF	(Maximum) length for defrost	0 to 255 min	30	Pr1
dSd	Start defrost delay	0 to 255 min	0	Pr2
dFd	Displaying during defrost	rt; it; SEt; dEF	it	Pr2
dAd	MAX display delay after defrost	0 to 255 min	30	Pr2
Fdt	Draining time	0 to 255 min	0	Pr2
dPo	First defrost after start-up	n; Y	n	Pr2
dAF	Defrost delay after fast freezing	0.0 to 24h00min, res. 10 min	0.0	Pr2
FnC	Fan operating mode	C-n; o-n; C-Y; o-Y	o-n	Pr1
Fnd	Fan delay after defrost	0 to 255 min	10	Pr1
FCT	Differential of temperature for forced activation of fans	[0 to 50°C] [0 to 90°F]	10	Pr2
FSt	Fan stop temperature	[-55 to 50.0°C] [-67 to 122°F]	2	Pr1
Fon	Fan on time with compressor off	0 to 15 min	0	Pr2
FoF	Fan off time with compressor off	0 to 15 min	0	Pr2
FAP	Probe selection for fan management	nP; P1; P2; P3; P4	P2	Pr2
ALC	Temperat. alarms configuration	rE; Ab	Ab	Pr2
ALU	MAXIMUM temperature alarm	Rel: [0.0 to 50.0°C] [0 to 90°F] AbS: [ALL to 150°C] [ALL to 302°F]	110.0	Pr1
ALL	Minimum temperature alarm	Rel: [0.0 to 50.0°C] [0 to 90°F] AbS: [-100°C to ALU] [-148°F to ALU]	-50.0	Pr1
AFH	Differential for temperat. alarm recovery	[0.1 to 25.5°C] [1 to 45°F]	1.0	Pr2
ALd	Temperature alarm delay	0 to 255 min	15	Pr2
dAo	Delay of temperature alarm at start up	0.0 to 24h00min, res. 10 min	1.3	Pr2
AP2	Probe for temperat. alarm of condenser	nP; P1; P2; P3; P4	P4	Pr2
AL2	Condenser for low temperat. alarm	[-100 to 150°C] [-148 to 302°F]	-40	Pr2
AU2	Condenser for high temperat. alarm	[-100 to 150°C] [-148 to 302°F]	110	Pr2
AH2	Differ. for condenser temp. alar. recovery	[0.1 to 25.5°C] [1 to 45°F]	5	Pr2
Ad2	Condenser temperature alarm delay	0 to 254 min, 255(nu)	15	Pr2
dA2	Delay of cond. temper. alarm at start up	0.0 to 24h00min, res. 10 min	1.3	Pr2
bLL	Compr. off for condenser low temperature alarm	n; Y	n	Pr2
AC2	Compr. off for condenser high temperature alarm	n; Y	n	Pr2
tbA	Alarm relay disabling	n; Y	Y	Pr2
oA3	Fourth relay configuration	ALr = alarm; dEF = do not select it; LiG = Light; AUS = AUX; onF = always on; FAn = do not select it; db = neutral zone; CP2 = second compressor; dF2 = do not select it	ALr	Pr2
AOp	Alarm relay polarity (oA3=ALr)	oP; CL	CL	Pr2
i1P	Digital input polarity (18-19)	oP; CL	CL	Pr1
i1F	Digital input configuration (18-19)	EAL; bAL; PAL; dor; dEF; ES; AUS; Htr; FAn; HdF; onF	dor	Pr1
did	Digital input alarm delay (18-20)	0 to 255 min	15	Pr1

Label	Name	Range	Value	Level
nPS	Number of activation of pressure switch	0 to 15	15	Pr2
odC	Compress and fan status when open door	no; FAn; CPR; F-C	F-C	Pr2
rrd	Regulation restart with door open alarm	n; Y	Y	Pr2
HES	Differential for Energy Saving	[-30 to 30°C] [-54 to 54°F]	0	Pr2
Adr	Serial address	0 to 247	1	Pr2
PbC	Kind of probe	PtC; ntC	ntC	Pr2
onF	on/off key enabling	nu; oFF; ES	nu	Pr2
dP1	Room probe display	probe value	-	Pr1
dP2	Evaporator probe display	probe value	-	Pr1
dP3	Third probe display	probe value	-	Pr1
dP4	Fourth probe display	probe value	-	Pr1
rSE	Real set	actual set	-	Pr2
rEL	Software release	read only	-	Pr2
Ptb	Map code	read only	-	Pr2

Dixell



Dixell S.r.l. - Z.I. Via dell'Industria, 27 - 32010 Pieve d'Alpago (BL) ITALY
Tel. +39.0437.98333 r.a. - Fax +39.0437.989313 - EmersonClimate.com/Dixell - dixell@emerson.com

DIXELL XR60 / XR70

Kod	İsim	Araç	FACTORY SETTING	PLUG-IN NEPTUN DD
Set	Ayar değeri	LS-US	-5.0	-2.4
Hy	Fark değeri	0.1-25.5 (C) / 1-25.5 (F)	2.0	4
LS	Araç ayar değeri	-50 (C) / SET - 55 (F) / SET	-60.0	-30
US	Azami ayar değeri	SET+110 (C) / SET + 230 (F)	110	-18
On	Termostat sensör kalibrasyonu	-12-12 (C) / -120-120 (F)	0.0	0
P2P	Evaporatör sensör yığılı	Her yıl Yıyay	Y	Y
OE	Evaporatör sensör kalibrasyonu	-12-12 (C) / -120-120 (F)	0.0	0
P3P	Üçüncü sensör yığılı	Her yıl Yıyay	n	n
O3	Üçüncü sensör kalibrasyonu	-12-12 (C) / -120-120 (F)	0	0
P4P	Dördüncü sensör yığılı	Her yıl Yıyay	n	n
O4	Dördüncü sensör kalibrasyonu	-12-12 (C) / -120-120 (F)	0	0
O6S	Kalibrasyon geçilmesi	0-255 dakika	0	0
AC	Kompresör bekleme süresi	0-50 dakika	1	0
nr	P1-P2 duzlenme süresi	0-100,100xP1, 0xP2	100	100
CO	Sıcaklığı kontrol süresi	0.0-24.0 saat	0.0	-
CCS	Sıcaklığı kontrol süresi değeri	(-95.0-150.0 (C) / -107-302 (F))	-6	-
COh	Sensör arızası ile kompresör açılış süresi	0-255 dakika	15	0
COF	Sensör arızası ile kompresör kapanış süresi	0-255 dakika	30	1
CF	Sıcaklık sınırı	C / F	C	C
ES	Gösterim	mmkcar, de, onaklık	de	de
Led	Sensör gösterimi	P1 P2	P1	P1
Ea	X-REP gösterimi	P1, P2, P3, P4, SEL, de	P1	P1
ELY	Sıcaklık gösterim geçilmesi	0-20.0 mm (10 saniye)	0	0
dtr	P1-P2 yığılı gösterim	1-99	50	50
de	Dehşet tipi	EL,elektrik, me sacak gar	EL	n
de	Dehşet süzlenme süresi	40-50 (C)	8	14
de	Dehşet arızaları	1-120 saat	6	6
MEP	Azami dehşet süzlenme süresi	0-255 dakika	30	40
de	Dehşet başlangıç geçilmesi	0-99 dakika	0	0
de	Dehşet arızası gösterim	n, t, SEL, DEF	e	n
da	Dehşet sonrası azami gösterim geçilmesi	0-255 dakika	30	0

es	Dijital giriş alarm geçilmesi	0-255 dakika	15	0
eps	Bilgiç olumsuz kontrolün sayısı	0-15	15	-
ec	Ayar yapıldığında kompresör durumu	no Fan, Cb, F, C	F, C	no
re	Fan hız alarmında düzenleme yeniden başlatması	n = Y	Y	Y
RES	Emniyet sensörü için fark değeri	130 (C) - 10 (C) / 54 (F) - 54 (F)	0	-
Pbc	Sensör türü	Pbc, rtc	1	rtc
enF	Kalibrasyon geçilmesi	no, off, ES	rtc	ES
ep1	Özellikler	-	no	-
ep2	Evaporatör sensör gösterim	-	-	-
ep3	Üçüncü sensör gösterim	-	-	-
ep4	Dördüncü sensör gösterim	-	-	-
ISE	Genç ayar değeri	ayar değeri	-	-
REL	Software versiyonu	-	-	-
Ptb	Parametre kodu	-	-	-

Fdt	Drinaj süresi	0-120 dakika	0	3
ep	Kapaktan sonraki dehşet	mmEP, süzlenme süresi, yığılı	n	n
ep	Hız ayarlaması için dehşet geçilmesi	0-23 saat 50 dakika	0.0	0
Fnc	Fan çalışma modu	Cb, on, Cb, on	on	C, n
End	Dehşet sonrası fan geçilmesi	0-255 dakika	10	4
Fet	Zorlanma fan arızası sırasında sıcaklık değeri	0-50 (C)	10	10
Fst	Fan dönme sıcaklığı	-60-90 (C) / -68-122 (F)	2	50
Fon	Kompresör kapalıyken fan açılış süresi	0-15 dakika	0	0
Fof	Kompresör kapalıyken fan kapanış süresi	0-15 dakika	0	0
ALc	Sıcaklık alarm konfigürasyonu	RE ayarı bağlı Ab = müdahale değeri	Ab	Ab
ALU	Azami sıcaklık değeri	Set: 110 (C) / Set: 230 (F)	110	20
ALL	Araç sıcaklık alarmı	-50.0 (C) / Set: -58 (F)	-50.0	-30
AFH	Sıcaklık alarmı düzenleme için fark değeri	(1 (C) - 2 (C) / 1 (F) - 45 (F))	1	1
ALb	Sıcaklık alarmı geçilmesi	0-255 dakika	15	0
da	Kalibrasyon sıcaklık değeri	0-23 saat 50 dakika	1.34	0
AL2	Kondansatör sıcaklık alarmı	(-65 + 150 (C) / (-67 + 302 (F))	-40	-
AL2	Kondansatör yüksek sıcaklık alarmı	(-65 + 150 (C) / (-67 + 302 (F))	110	-
AH2	Kondansatör sıcaklık alarmı düzenleme için fark ayar değeri	(0.1 (C) - 25 (C) / 1 (F) - 45 (F))	5	-
da	Kondansatör sıcaklık alarmı geçilmesi	0-254 (dakika) / 255 (nu)	15	-
da	Kalibrasyon sıcaklık alarmı geçilmesi	0.0-23h 50	1.3	-
BLL	Kondansatör düşük sıcaklık alarmında kompresör kapanması	n(0) - Y(1)	n	-
AC2	Kondansatör yüksek sıcaklık alarmında kompresör kapanması	n(0) - Y(1)	n	-
ISP	Dijital giriş pozisyonu	0-Parametre C1 + kapama	EL	-
ISF	Dijital giriş konfigürasyonu	EAL, BAL, PAL, dol, deF, Ht, AUS	off	-

Drg. No: WD_WSL_012
 Part: NEPTUN_PLUG_IN
 Title: NEPTUN_PLUG_IN
 Control: YAVUZ TÜRKÖĞLÜ
 Scale: 25.02.2021
 Drg. Date: 25.02.2021
 Where Used:
 Materials:
 Rev. No:
 Material Stock No:
 Material Supplier Name:
 Approved:
 Approved Date:
 Signed:

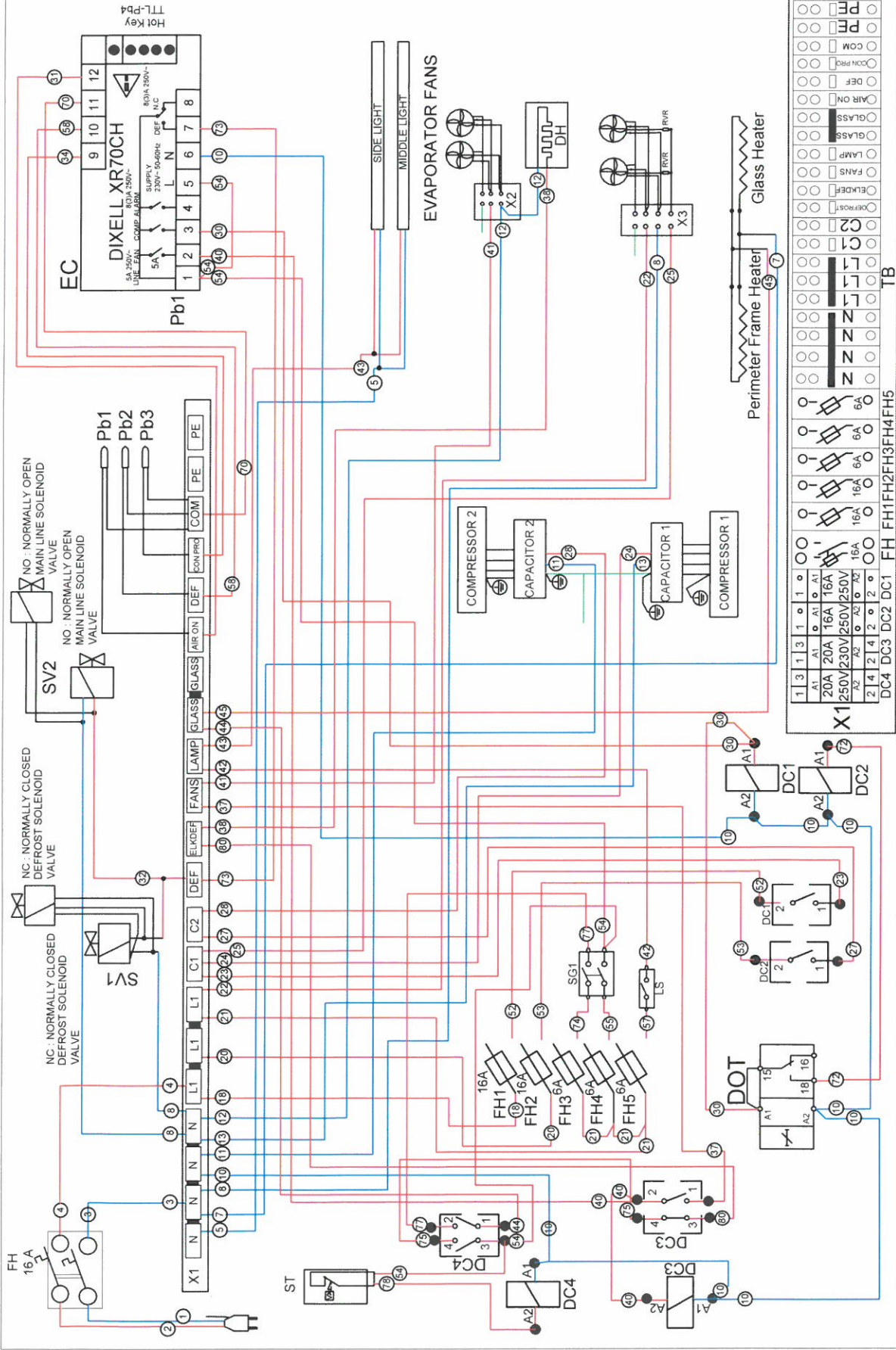

CODE	DESCRIPTION	CODE	DESCRIPTION
EC	ELECTRONIC CONTROLLER	DH	DEFROST HEATER
SG1	ON-OFF SWITCH	L	PHASE SUPPLY
LS	LIGHT SWITCH	N	NEUTRAL SUPPLY
FH	FUSE HOLDER (ON-OFF) (16A)	C1	COMPRESSOR 1
FH1	FUSE HOLDER (COMP 1) (16A)	C2	COMPRESSOR 2
FH2	FUSE HOLDER (COMP 2) (16A)	PE	EARTH
FH3	FUSE HOLDER (GLASS REZ) (6A)	TB	TERMINAL BOX
DC3	CONTACTOR (FANS , DEF REZ)	ST	SAFETY THERMOSTAT
DC4	CONTACTOR (GLASS REZ)	SV1	SOLENOID VALVE NORMALLY CLOSED
		SV2	SOLENOID VALVE NORMALLY OPEN